

SWIVELWHEEL-58DW TANDEM TOW

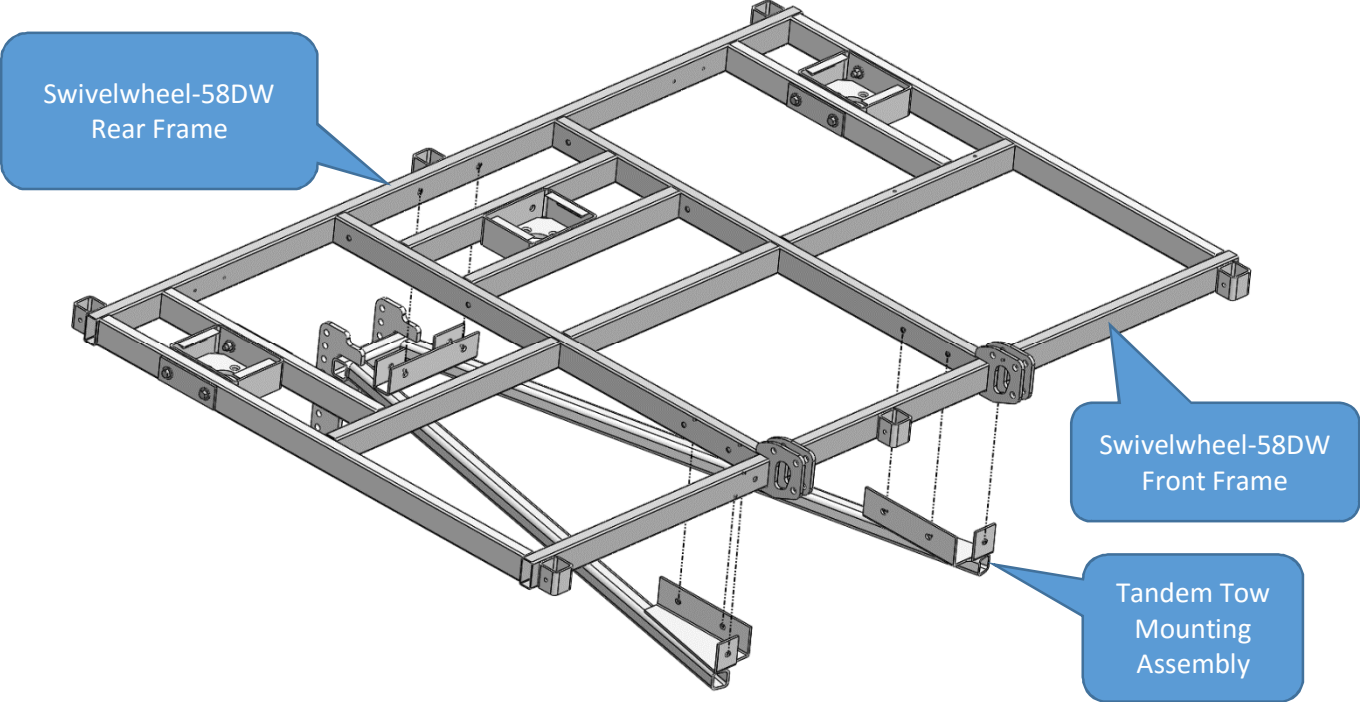

The Swivelwheel-58DW Tandem Tow allows the owners of the SWIVELWHEEL-58DW system the choice to tow a 6000 pound vehicle behind the SWIVELWHEEL-58 platform. **This option is not available for the SWIVELWHEEL-58 Single Wheel System.**

The Tandem Tow system is a result of customers asking for the ability to tow their car behind the Swivelwheel-58DW platform. This system has been a long time in the making with all of the engineering research needed in order to provide a product that is safe and reliable.



The engineering drawing above shows the layout for installation and the frame mounting hole's locations. Included with the system is a newly designed Rotational Hitch Bar Assembly as shown below.

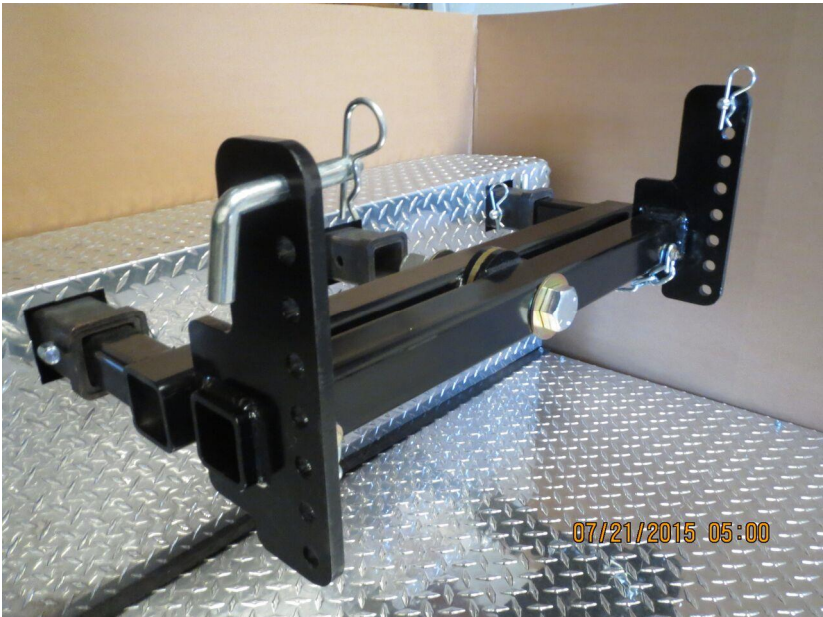

Assemble the Tandem Tow frame and slide it under the SWIVELWHEEL-59DW's frame as shown below and in the engineering drawing.

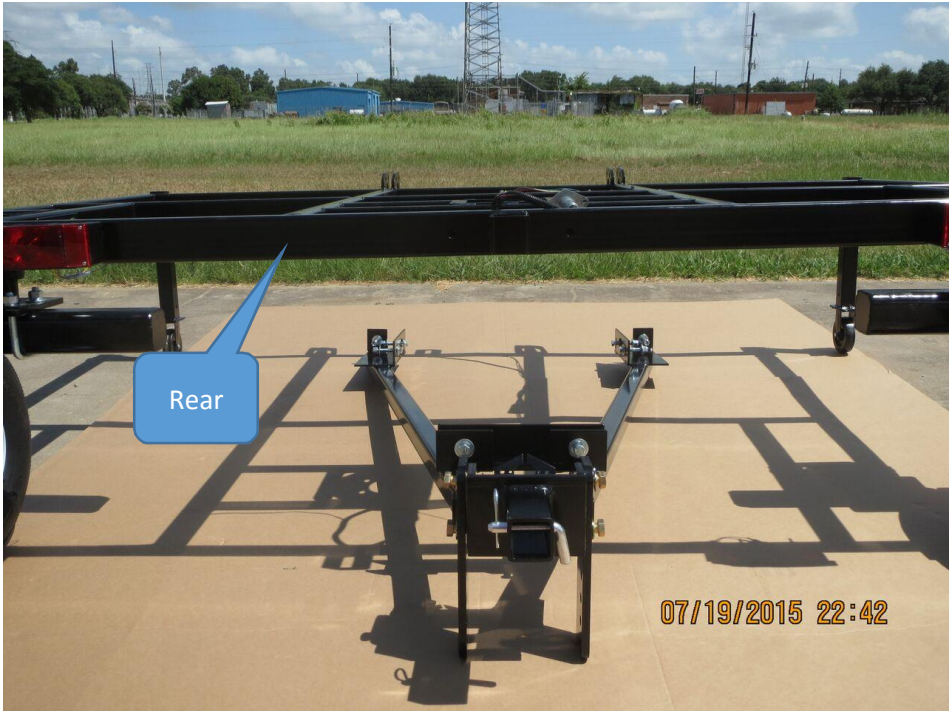

Lift the Tandem Tow frame up to the SWIVELWHEEL-58DW frame and clamp or block into position. With the supplied mounting bolts, bolt the system into place as shown in the following photos below. Once all mounting bolts are in position, tighten all nuts fully.

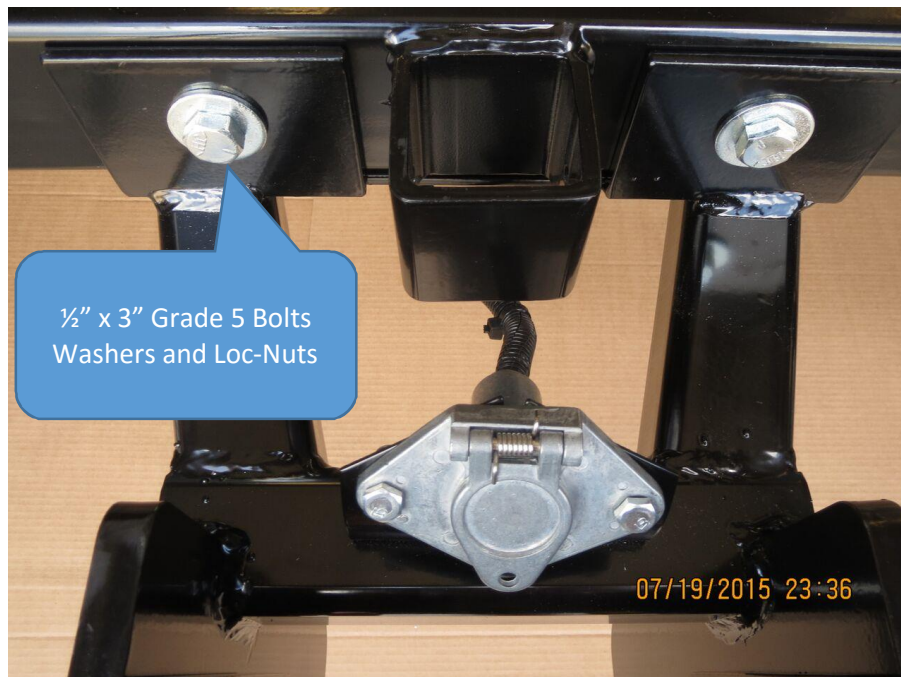
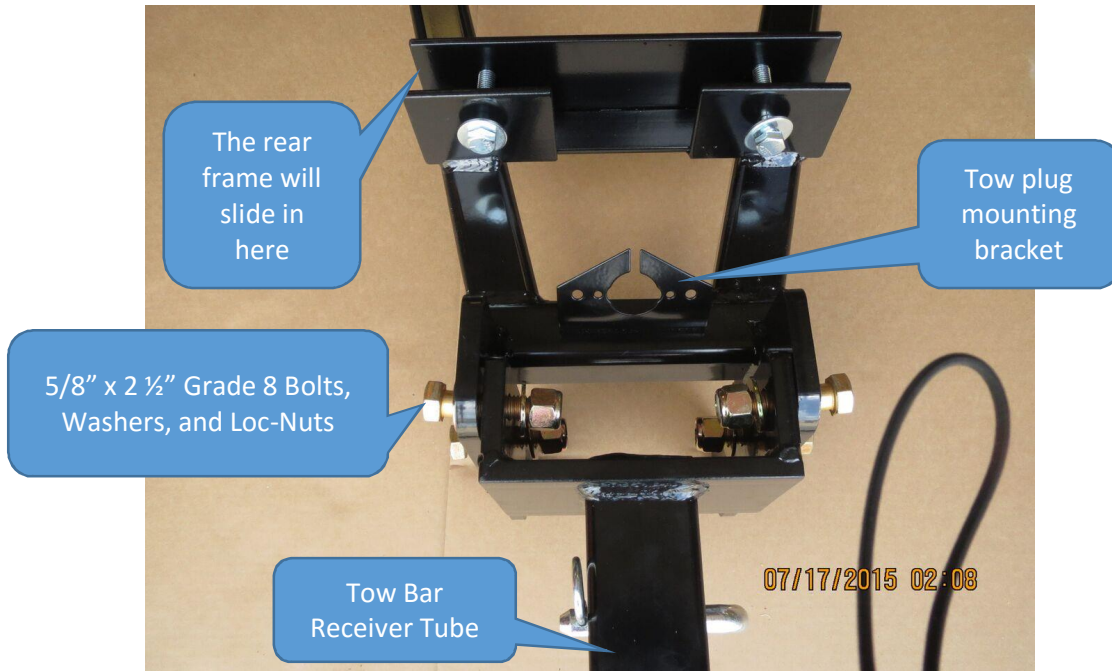

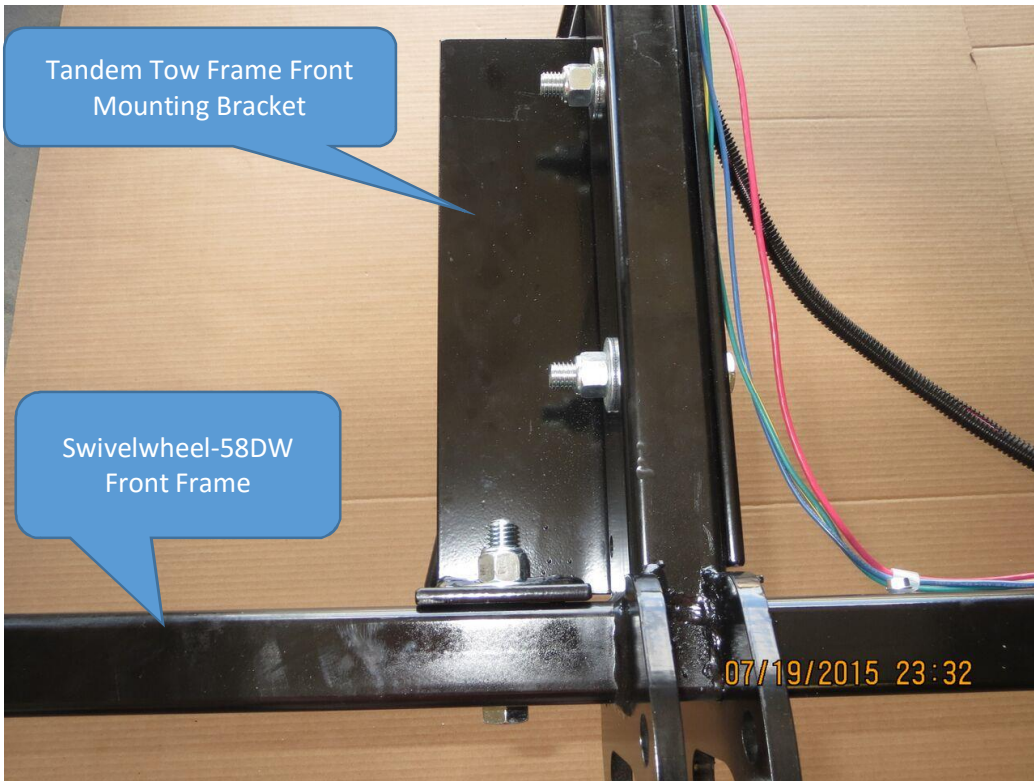
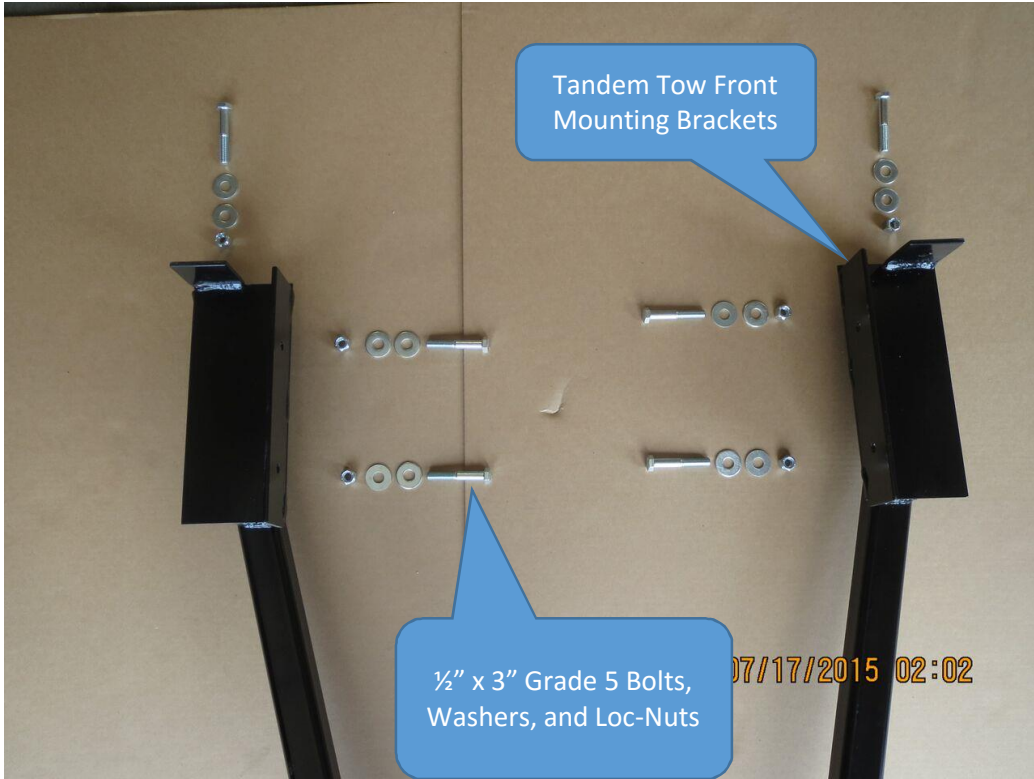

SWIVELWHEEL-58DW TANDEM TOW FACTS:

SYSTEM DECK WEIGHT LIMIT

- 1200 pounds evenly distributed across the deck.

MAXIMUM TOWED CAR WEIGHT LIMIT

- 6000 pounds being towed with all four tires on the ground.
- NO TOW DOLLIES
- No trailers or ball mounted devices behind the Swivelwheel-58DW Tandem Tow.
- No towing behind the Swivelwheel-58DW Tandem Tow with no load on the deck.

BACKING

- You cannot back up with the tow car attached to the rear of the swivelwheel-58DW Tandem Tow. System. The towed vehicles front tires will turn to the side and start skidding across the pavement, which could cause damage to the Swivelwheel-58DW from the applied forces.
- If the towed car is not attached, you can back up without any problems. The Swivelwheel-58DW system will always track with the towing vehicle. It will not jackknife.

BRAKING SYSTEM REQUIRED

- You MUST have a breaking system operating at all times in the towed car when being towed behind the Swivelwheel-58DW Tandem Tow receiver plates.

ADJUSTMENTS

- When hooking up your towed car to the Swivelwheel-58DW Tandem Tow system, you need to make sure that the tow bar going from the vehicle, into the system, is flat and parallel to the ground. This can be adjusted by moving the receiver tube up or down at the rear of the Swivelwheel to find the correct position so that the tow bar is as flat as possible. If you cannot get the tow bar perfectly flat, it is best to have it tilted slightly downward.

IMPORTANT: You do not want the tow bar in the upward position as it could, upon braking, try to lift the Swivelwheel-58DW off of the ground and cause damage to the motorhome and load.